

# BUILDING-IN MADE SIMPLE!



## Smasher™ XXL

### Next Generation ODM Building-in Machine – Smasher™ XXL

The ODM Smasher™ XXL has been re-engineered to produce 'library-quality' hard cover books from wallet-size up to tabloid size books. Smasher™ XXL machine is a self-adjusting, hydraulic building-in machine requiring no make-ready. Cost-effective bookbinding machine can produce 100 to 300 covers per hour. Ideal for entry-level hard cover bookbinding production. ODM machines are built in the USA and work seamlessly with ODM's Casemaking System™ and Sticker™ XXL Series.

Operator places the cased-in book into the Smasher™ XXL and depresses a foot pedal that brings the top joint iron in contact with the book. This enables the operator to accurately find the joint area of the book. After locating the joint area, two buttons are depressed that activate the hydraulic system that raises the bottom steel platen and clamps the book with 20,000 pounds of pressure. Heated joint irons aid in forming the joint by reactivating the adhesive in the joint area and softening hard cover materials such as library buckram and film laminates. Smasher™ XXL has an adjustable dwell timer that controls how long the book remains under pressure. Heated joint irons have a thermostat for varying the degree of temperature.

**ODM Smasher™ XXL is designed for forming the joints and pressing (building-in) hard cover books.**

- Produce wallet size (4" x 4") to oversize tabloid (18" x 18") hard cover books from 1/32" to 4" thick; 100 to 300 books per hour.

#### FEATURES:

- Easy to operate controls.
- Dual button operation insures operator safety.
- Ten tons of hydraulic pressure produces highly compressed books
- Adjustable dwell timer controls how long book remains under pressure.
- Thermostat control for heated joint irons aid in forming a perfect joint.



**STEP 1**  
The operator places the cased-in book into the Smasher and steps on a foot pedal to find the joint area of the book.

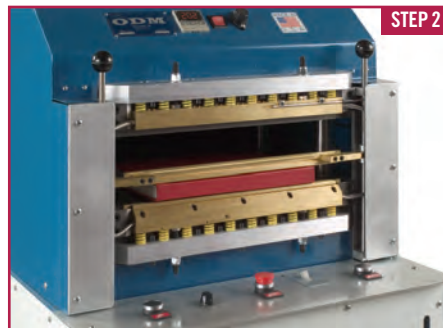

**STEP 2**  
The operator uses a foot pedal to find the joint area then activates the hydraulic clamping pressure.

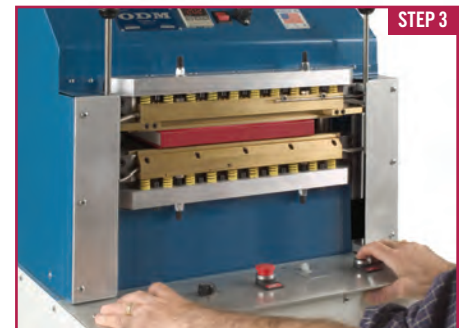

**STEP 3**  
The book is clamped between two steel platens and the joint area is pressed with heated irons that help form the joint.

# Smasher™ XXL



## ODM BUILDING-IN MACHINE

*Smasher™ XXL Building-in Machine Offers Outstanding Value, Quality, and Performance!*

SPECIFICATIONS & TECHNICAL DATA:	SMASHER™ XXL MODEL	STANDARD EQUIPMENT for SMASHER™ XXL BUILDING-IN MACHINE INCLUDES:
Maximum Book Size:	18" x 18" x 4"	<ul style="list-style-type: none"> <li>• Easy to operate control panel.</li> <li>• Dual button operation insures operator safety.</li> <li>• Ten tons of hydraulic pressure produces highly compressed books.</li> <li>• Adjustable dwell timer controls the amount of time the book remains under pressure.</li> <li>• Thermostat control for heated joint irons aid in forming a perfect joint.</li> <li>• Produce wallet to tabloid size hard cover books.</li> </ul>
Minimum Book Size:	4" x 4" x 1/32"	
Output (per hour):	100 to 300 books	
Floor Space:	28" x 28"	
Net Weight:	1150 lbs.	
Power Required:	(2) 115 Volt, 60 cycle 14 Amp lines	

**DIMENSIONS: FRONT VIEW**

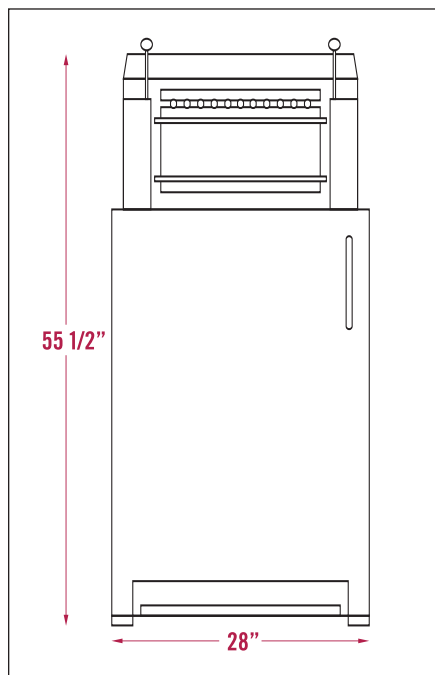

**SIDE VIEW**

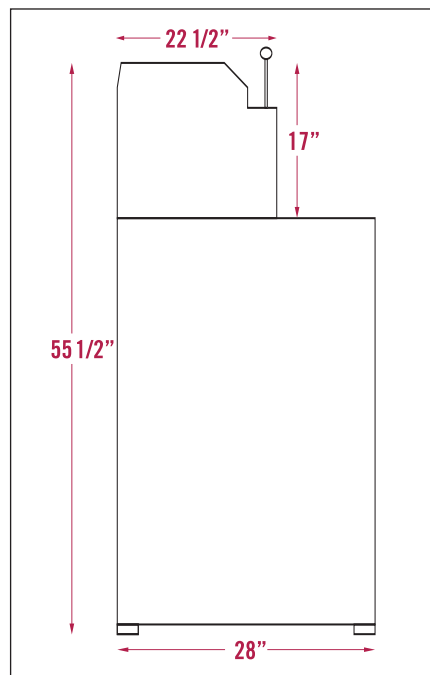

**OVERHEAD VIEW**

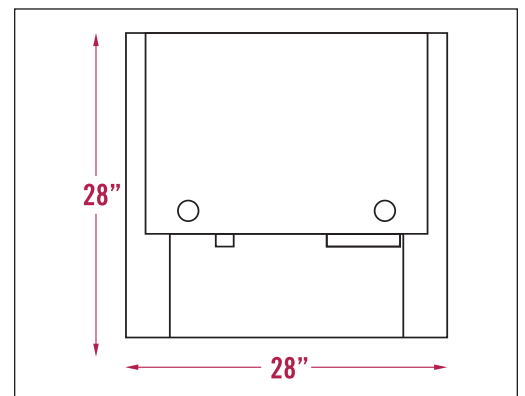

Finished 'libaray-quality' hard cover tabloid book that will last for many future generations to enjoy.



**ODM FREE TECH SUPPORT: 908-351-6906**

150 Broadway, Elizabeth, NJ 07206 • Tel: 908-351-6906 • Fax: 908-351-7156 • [www.ODMachinery.com](http://www.ODMachinery.com)